

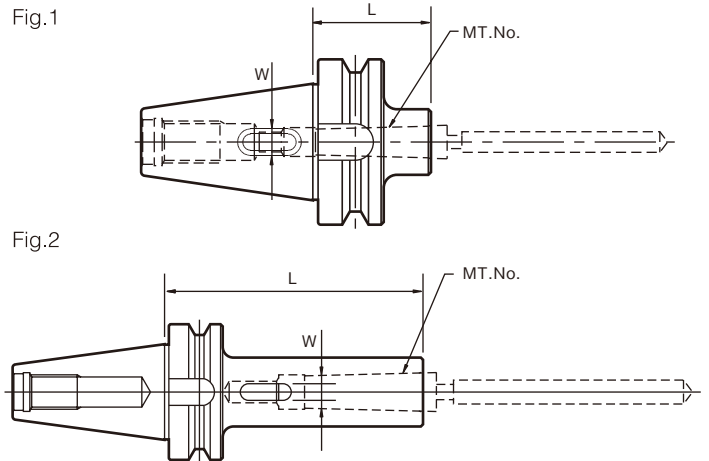

MA Morse Taper Adapter (tang type)

BT/SK

● Min. 80% taper fit



Taper	Code. No	MT No.	L	W	Fig
BT40 (SK40)	BT40-MA1-045	1	45	5.6	1
	BT40-MA2-060	2	60	6.6	1
	BT40-MA3-075	3	75	8.4	1
	BT40-MA3-135		135		2
BT50 (SK50)	BT50-MA2-060	2	60	6.6	1
	BT50-MA2-135		135		2
	BT50-MA2-200*		200		2
	BT50-MA2-250*		250		2
	BT50-MA2-300*		300		2
	BT50-MA2-350*		350		2
	BT50-MA3-065	3	65	8.4	1
	BT50-MA3-150		150		2
	BT50-MA3-180		180		2
	BT50-MA3-200*		200		2
	BT50-MA3-250*		250		2
	BT50-MA3-300*		300		2
	BT50-MA3-350*	350	2		
	BT50-MA4-095	4	95	12.4	1
	BT50-MA4-180		180		2
	BT50-MA4-200*		200		2
	BT50-MA4-250*		250		2
	BT50-MA4-300*		300		2
	BT50-MA4-350*		350		2
	BT50-MA5-105	5	105	16.5	1
BT50-MA5-200*	200		2		
BT50-MA5-250*	250		2		
BT50-MA5-300*	300		2		
BT50-MA5-350*	350		2		

*Not regular stock items. Please ask for availability.



Pull Stud

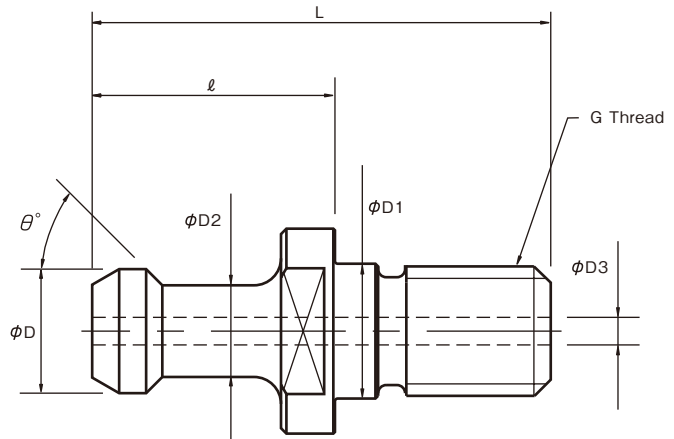

It is critical that the correct pull stud is used with each machining center. Please verify all dimensions prior to ordering. Machine specifications will be located in your machine manual.

Spindle	Code No.	ϕD	L	l	D2	D1	G	θ°	D3	Note
BT30	HPS-16	11	43	23	7	12.5	M12	45	-	MAS P30T-1
	HPS-16C	11	43	23	7	12.5	M12	45	2.5	HPS-16 Coolant
	HPS-17	11	43	23	7	12.5	M12	60	-	MAS P30T-2
	HPS-17C	11	43	23	7	12.5	M12	60	2.5	HPS-17 Coolant
BT40	HPS- 1	15	60	35	10	17	M16	45	-	MAS P40T-1
	HPS- 2	15	60	35	10	17	M16	60	-	MAS P40T-2
	HPS-806-1	19	54	29	14	17	M16	75	6	JIS B6339. Coolant
	HPS-G51	18.796	44.106	19.106	12.446	17	M16	45	7	Mazak type. Coolant
	HPS-O8	15	60	35	10	17	M16	90	-	90 degree angle type
	HPS-301	15	60	35	11	17	M16	60	-	
	HPS-302	19	54	26	14	17	M16	75	-	DIN69872.
	HPS-366E-1	19	54	29	14	17	M16	75	7	P-9, S 15 O-ring
	HPS-805	19	54	29	14	17	M16	75	-	JIS B6339-89
	HPS-813-1	19	54	29	14	17	M16	75	6	JIS B6339-89
HPS-B62-1	19	54	29	14	17	M16	75	4	S 15 O-ring	
BT50	HPS- 5	23	85	45	17	25	M24	45	-	MAS P50T-1
	HPS- 6	23	85	45	17	25	M24	60	-	MAS P50T-2
	HPS-G41	28.956	65.2	25.2	20.828	25	M24	45	10	
SK30	HPS-122	13	44	24	9	13	M12	75	-	DIN69872 SK30 FORM A
SK40	HPS-302	19	54	26	14	17	M16	75	-	DIN69872 SK40 FORM A
	HPS-309	19	54	26	14	17	M16	75	7	DIN69872 SK40 FORM A Coolant
	HPS-309C	19	54	26	14	17	M16	75	7	DIN69872 SK40 FORM B
	HPS-A1	19	54	26	14	17	M16	75	7	ISO-7388/2-1984-A
	HPS-A4	18.95	44.5	16.4	12.95	17	M16	45	7.35	ISO-7388/2-1984-B
SK50	HPS-581	28	74	34	21	25	M24	75	-	DIN69872 SK50 FORM A
	HPS-512	28	74	34	21	25	M24	75	11.5	DIN69872 SK50 FORM A Coolant
	HPS-512B	28	74	34	21	25	M24	75	11.5	DIN69872 SK50 FORM B
	HPS-A3	28	74	34	21	25	M24	75	11.5	ISO-7388/2-1984-A
	HPS-A6	29.1	65.5	25.55	19.6	25	M24	45	11.55	ISO-7388/2-1984-B

◇Other Pull Studs are available upon request.